

Vannes by-pass, INTERPUMP

HM

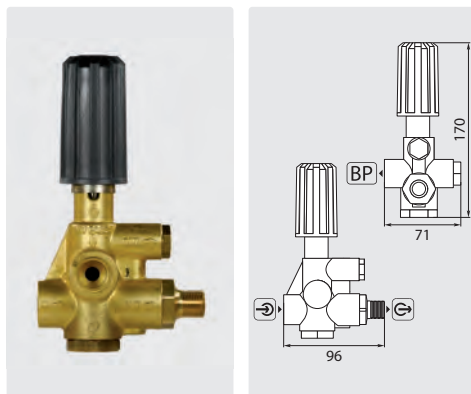

☉ = entrée 3/8" F. ☉ = sortie 3/8" M.
BP = by-pass 3/8" F. MN = manomètre 1/4" F.
Max. 200 bar / 85 °C

R+M Nr.	☉
010 002 00	5 - 41 l/min

BKX

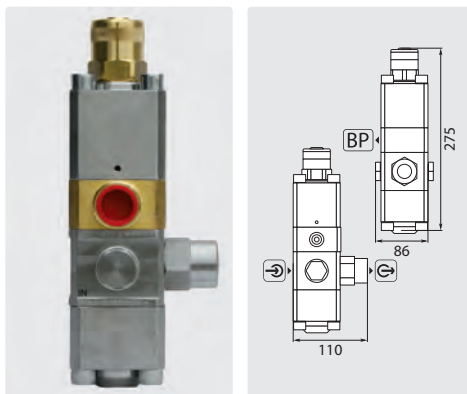

☉ = entrée 1/2" F. ☉ = sortie 1/2" F.
BP = by-pass 3/4" F.
Max. 600 bar / 60 °C

R+M Nr.	☉
010 000 02	60 l/min

TIMAX

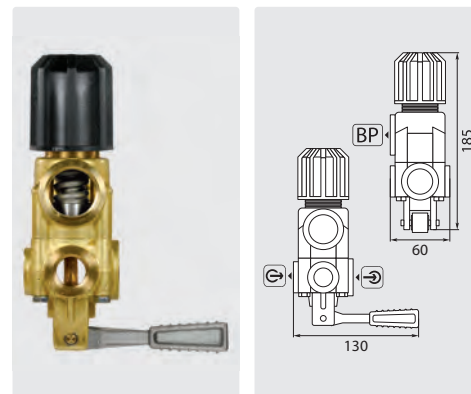

☉ = entrée 3/4" F. ☉ = sortie 1/2" F.
BP = by-pass 1" F.
Max. 60 bar / 60 °C

R+M Nr.	☉
010 010 01	200 l/min

Kits de réparation



R+M Nr.	Kit Nr.	TYP
340 058 01	58	K5
340 060 01	60	K5
340 070 01	70	K7
340 072 01	72	HM
340 093 01	93	W2, W2L
340 094 01	94	W2, W2L

Kit de réparation BKX

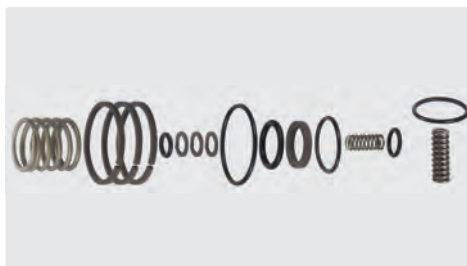

R+M Nr.	010 000 03
---------	------------

Vanne "easystart"



Soupape de démarrage pour tempérer la montée en pression pendant la phase de démarrage de la pompe HP. Laiton / acier inoxydable. Fermeture à 4 l/min. Max. 350 bar / 150 °C

R+M Nr.	☉	☉
200 232 510	3/8" M	1/4" M

Régulateurs de vitesse pour moteurs thermiques

IP, ajustable



Régulateur avec câble et gaine 1.000 mm.
Min. 50 bar. Max. 200 bar / 75 °C

R+M Nr.	☉
995 000 00	3/8" M

RG1

Permet la réduction de la vitesse de rotation du moteur en phase by-pass



☉ 1/4" M. 15-250 bar - 218-3.650 psi.
Max. 160 °C

R+M Nr.	Course	☉
532 013 0	14 mm	158 g

Symboles ☉ entrée ☉ sortie BP by-pass MN manomètre ☉ débit TYP type ☉ poids ☉ filetage