

## Enrouleurs automatiques haute-pression

R+M 544

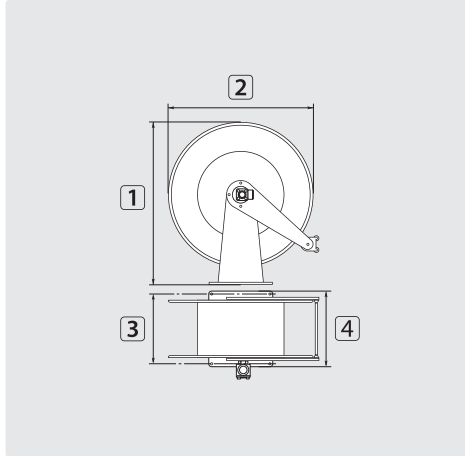

TYP	extérieur	∅ = tuyau	↔
03	22,0 mm	= 30 m	
03	28,0 mm	= 22 m	
03	34,0 mm	= 17 m	

R+M Nr.	★	Ⓒ	Ⓔ	DN	P	°C	Ⓢ	1	2	3	4	TYP
763 544 30	■	1/2" F	1/2" F	12	300 bar	90 °C	24,0 kg	573 mm	510 mm	218 mm	300 mm	03
763 544 20	■	1" F	1" F	19	100 bar	90 °C	24,0 kg	573 mm	510 mm	218 mm	300 mm	03

R+M 564

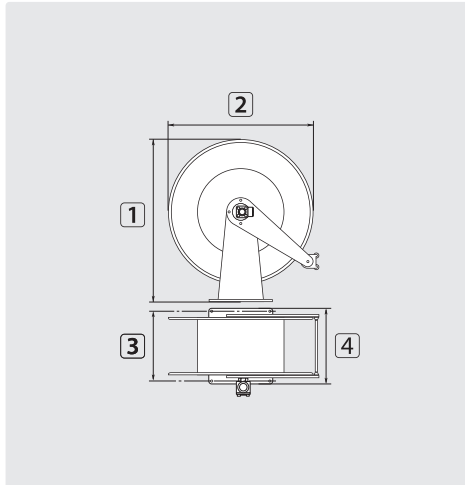

TYP	extérieur	∅ = tuyau	↔
04	22,0 mm	= 60 m	
04	30,0 mm	= 40 m	
04	35,0 mm	= 30 m	

R+M Nr.	★	Ⓒ	Ⓔ	DN	P	°C	Ⓢ	1	2	3	4	TYP
763 564 30	▼	1/2" F	1/2" F	12	300 bar	90 °C	30,0 kg	578 mm	510 mm	399 mm	488 mm	04

Symboles ★ repaire Ⓒ entrée Ⓔ sortie DN diamètre nominal P pression ↔ longueur Ⓢ poids TYP type °C température 1 hauteur