

Accessories for wall cleaner

new

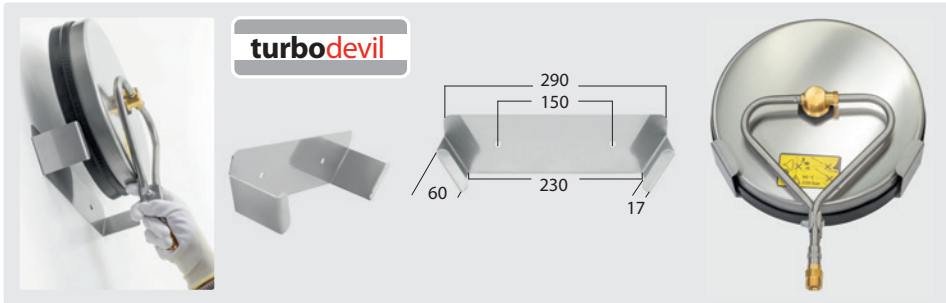

Wall bracket for wall cleaner **turbodevil**.

R+M Nr.	M	5
710 400 097	stainless steel 2 mm	502 gr

hydroblade® Nozzle System

Set consists of nozzle holder, 6 equal nozzles and O-rings.
Max. 400 bar / 150 °C

- » Strong and uniform flat jet with extraordinarily narrow jet depth
- » Application: High pressure and steam jet cleaning
- » Suitable for existing systems
- » Stainless steel

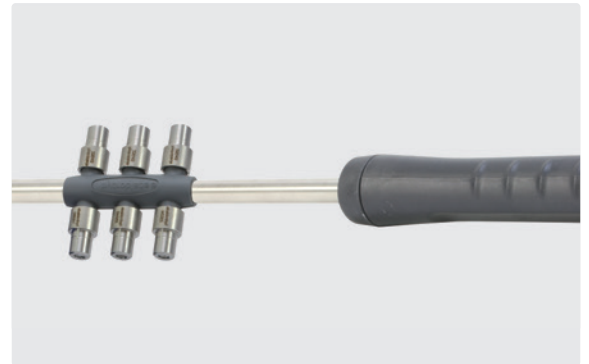

	0°	15°	25°	40°
D				
034		126 015 034	126 025 034	
040	126 100 040	126 015 040	126 025 040	126 040 040
045	126 100 045	126 015 045	126 025 045	126 040 045
050	126 100 050	126 015 050	126 025 050	126 040 050
055	126 100 055	126 015 055	126 025 055	126 040 055
060	126 100 060	126 015 060	126 025 060	126 040 060
065			126 025 065	
070		126 015 070	126 025 070	126 040 070
075	126 100 075	126 015 075	126 025 075	
080		126 015 080	126 025 080	
090			126 025 090	
100			126 025 100	

hydroblade® Benchmark

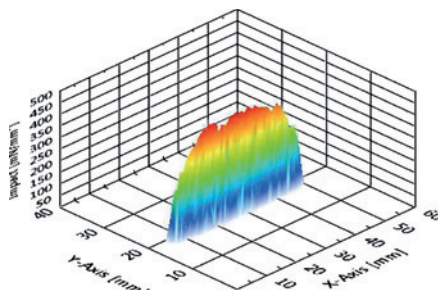
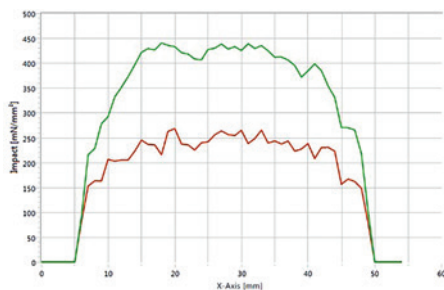

hydroblade® flat jet nozzles feature a homogenous liquid and pressure distribution. Highly efficient jets are achieved with spray angles of up to 40°. Thanks to the flow geometry of the nozzles, a compact and controlled jet is generated.

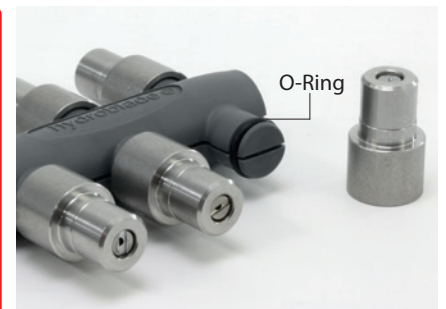

The **hydroblade®** set consists of nozzle holder, 6 equal nozzles, and corresponding O-rings.

new

1/4" F : M20 M.
Nozzle holder.
Stainless steel

R+M Nr.	200 088 125
---------	-------------

new

M20x1 F.
Nozzle protector.
Brass

R+M Nr.	020 000 085
---------	-------------