

Regulation valves

UL 250

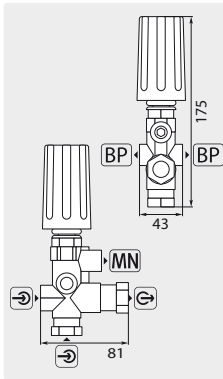

☉ = inlet 3/8" F. ☉ = outlet 3/8" F. [BP] = bypass 1/4" F. [MN] = pressure gauge 1/4" F. Ball check valve. Max. 250 bar / 60 °C

R+M Nr.	☰
533 31	35 l/min

UL 250 for panel mounting

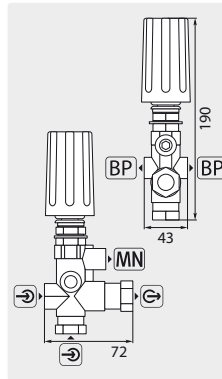

☉ = inlet 3/8" F. ☉ = outlet 3/8" F. [BP] = bypass 1/4" F. [MN] = pressure gauge 1/4" F. Ball check valve. Max. 250 bar / 60 °C

R+M Nr.	☰
533 351	35 l/min

UL 250

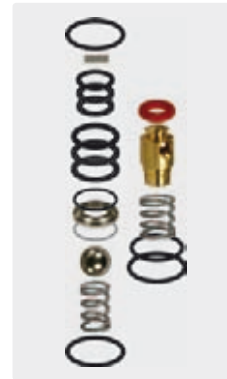

Standard



With ball check valve

R+M Nr.	R+M Nr.
121 412 9	121 412 91

VB7



☉ = input 3/8" M. ☉ = outlet 3/8" F. [BP] = bypass 3/8" F. [MN] = pressure gauge 1/4" F. Max. 220 bar / 90 °C

R+M Nr.	☰
532 722 0	30 l/min

VB9



☉ = inlet 3/8" F. ☉ = outlet 3/8" F. [BP] = bypass 3/8" F. [MN] = pressure gauge 1/4" F. Regulation valve with switch (IP55) and cable 1000 mm. Max. 220 bar / 90 °C

R+M Nr.	☰
532 235 0	30 l/min

VB9



☉ = inlet 3/8" F. ☉ = outlet 3/8" F. [BP] = bypass 3/8" F. [MN] = pressure gauge 1/4" F. Max. 220 bar / 90 °C

R+M Nr.	☰
532 234 0	30 l/min

VB56



☉ = inlet 1/2" F. ☉ = outlet 3/8" F. Regulation valve with banjo-bolt. X: 26 mm. Y: 66 - 76 mm. Suitable for Leuco or Hawk MT-LT / CAT 5CP. Max. 220 bar / 90 °C

R+M Nr.	☰
532 137 2	30 l/min



☉ = inlet 1/2" F. ☉ = outlet 3/8" F. Regulation valve with banjo-bolt. X: 4.5 mm. Y: 59.5 - 63.5 mm. Suitable for AR Serie RC. Max. 220 bar / 90 °C

R+M Nr.	☰
532 139 2	30 l/min



☉ = inlet 1/2" F. ☉ = outlet 3/8" F. Regulation valve with banjo-bolt. X: 4.5 mm. Y: 62 - 65.5 mm. Suitable for AR Series RK, Comet Series FW. Max. 220 bar / 90 °C

R+M Nr.	☰
532 138 0	30 l/min