

High pressure hose reels

STKI

The STKI series suitable for applications in craft and industry:

- » The base frame is made out of canted steel sheet profiles which stand for excellent stability.
- » The drum rotates by means of an adjustable handwheel being equipped with a free-wheel polyamide grip.
- » By means of a mechanical brake integrated in the bearing the drum can be slowly decelerated or even totally blocked.

- » Suitable for the mediums water or water with cleaning detergent, air, oils and greases.
- » The hose reels are all equipped with a swivel ST-322. The swivels ST-322 are completely made out of stainless steel and have a slide ring as sealing element.

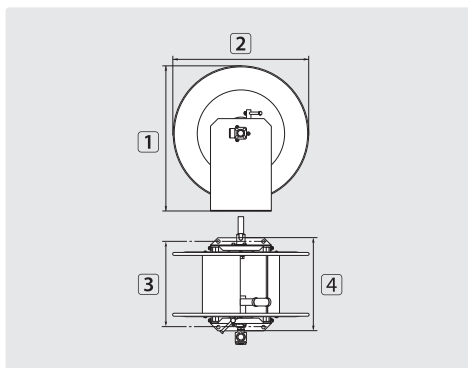

TYP	outer \varnothing = hose \leftrightarrow
01	22.0 mm = 35 m
02	22.0 mm = 70 m
03	22.0 mm = 100 m
04	22.0 mm = 115 m
05	28.0 mm = 20 m
06	28.0 mm = 40 m
07	28.0 mm = 60 m
08	28.0 mm = 70 m
09	28.0 mm = 80 m
10	35.0 mm = 61 m

Stainless steel V2A / AISI 304

R+M Nr.	\odot	\ominus	DN	P	$^{\circ}\text{C}$	\boxplus	1	2	3	4	TYP
739 50	1/2" F	1/2" F	10	300 bar	90 °C	10.5 kg	515 mm	465 mm	280 mm	312 mm	01
739 60	1/2" F	1/2" F	10	300 bar	90 °C	13.5 kg	515 mm	465 mm	480 mm	512 mm	02
739 65	1/2" F	1/2" F	10	300 bar	90 °C	15.7 kg	515 mm	465 mm	680 mm	712 mm	03
739 701 2	1/2" F	1/2" F	10	300 bar	90 °C	16.8 kg	515 mm	465 mm	780 mm	812 mm	04
739 501 9	3/4" F	3/4" F	19	200 bar	90 °C	11.7 kg	515 mm	465 mm	280 mm	312 mm	05
739 601 9	3/4" F	3/4" F	19	200 bar	90 °C	14.7 kg	515 mm	465 mm	480 mm	512 mm	06
739 651 9	3/4" F	3/4" F	19	200 bar	90 °C	16.9 kg	515 mm	465 mm	680 mm	712 mm	07
739 70	3/4" F	3/4" F	19	200 bar	90 °C	18.0 kg	515 mm	465 mm	780 mm	812 mm	08
739 801 9	3/4" F	3/4" F	19	200 bar	90 °C	19.1 kg	515 mm	465 mm	880 mm	912 mm	09
739 702 4	1" F	1" F	24	100 bar	90 °C	18.3 kg	515 mm	465 mm	780 mm	812 mm	10

Accessories for hose reels

Elbow swivels



3/8" F : 3/8" M. DN 10.
Max. 400 bar / 90 °C

R+M Nr.	1
200 322 500	65 mm



1/2" F : 3/8" M. DN 10.
Max. 300 bar / 90 °C

R+M Nr.	1
200 322 510	65 mm



1/2" F : 1/2" M. DN 12.
Max. 300 bar / 90 °C

R+M Nr.	1
200 322 520	67 mm



1/2" F : 1/2" M. DN 12.
Max. 300 bar / 90 °C

R+M Nr.	1
200 322 522	68 mm

ST / SoST



Swivel 200 bar

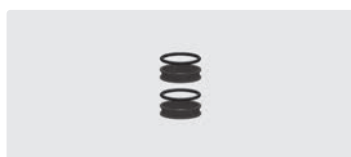

Repair kit swivel 750 400 1

R+M Nr.	\odot
750 400 1	3/4"

R+M Nr.	TYP
750 400 2	3/4"

Symbols \odot inlet \ominus outlet DN nominal diameter P pressure 1 height \leftrightarrow length \boxplus weight \odot thread TYP type shipment by truck