

High pressure hose reels

ST-71

- » The base frame is made out of stainless steel V2A / AISI 304 and stands for highest stability.
- » Equipped with an especially wide orifice of 12 mm.
- » Suitable media: water or water with cleaning chemicals, air, oils and grease.
- » The drum hub consists of 5 sturdy stainless steel rods and runs in specially maintenance-free bearing sleeves.
- » The drum rotates by means of an adjustable handwheel being equipped with a free-wheel polyamide grip.
- » A mechanical brake makes it possible to lock in 6 positions.
- » This high pressure hose reel is equipped with the swivel ST-322.
- » The Suttner swivels ST-322 are completely made out of stainless steel and have a slide-ring sealing element.
- » Not suitable for being mounted at walls and ceiling.

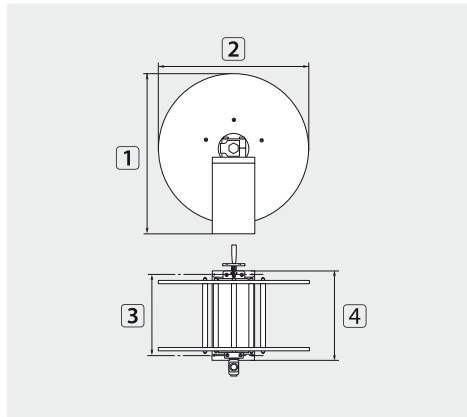

TYP	outer ∅ = hose ⇄
01	22.0 mm = 40 m

Stainless steel V2A / AISI 304

R+M Nr.	Ⓒ	Ⓓ	DN	P	°C	Ⓔ	1	2	3	4	TYP
200 071 705	1/2" F	1/2" F	12	300 bar	90 °C	13 kg	460 mm	440 mm	240 mm	290 mm	01

Accessories for ST-71

Swivels ST-322



Repair kit swivel ST-322

R+M Nr.
200 322 490

1/2" F : 1/2" M. DN 12.
Max. 300 bar / 30 r.p.m. / 90 °C

R+M Nr.	1
200 322 520	67 mm

Symbols TYP type 1 height Ⓒ inlet Ⓓ outlet DN nominal diameter P pressure ⇄ length ∅ diameter