

ST-550 foot valves



Housing stainless steel.
Valve stainless steel.
Rubber feet.
Max. 500 bar / 80 l/min / 150 °C



Housing stainless steel.
Valve stainless steel.
Rubber feet.
Max. 500 bar / 80 l/min / 150 °C

R+M Nr.	↔	⊕
200 550 600	1/4" F	1/4" F

R+M Nr.	↔	⊕
200 550 620	M22 F	M22 M

ST-540 foot valve



Incl. HP-gun ST-2750.
Material housing powdercoated steel.
Rubber feet.
Max. 500 bar / 30 l/min / 150 °C

R+M Nr.	↔	⊕
200 540 550	1/4" M	3/8" F



Incl. HP-gun ST-2750.
Material housing powdercoated steel.
Rubber feet.
Max. 500 bar / 30 l/min / 150 °C

R+M Nr.	↔	⊕
200 540 560	M22 M	M22 M

Ultra high pressure ball valves

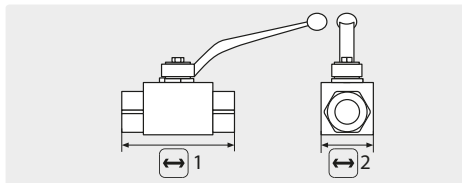

Stainless steel V4A / AISI 316 Ti. Ball stainless steel.
Max. 500 bar / 80 °C

R+M Nr.	↔ 1	↔ 2	⊕
707 15	69 mm	26 mm	1/4" F
707 25	72 mm	32 mm	3/8" F
707 35	83 mm	35 mm	1/2" F

Sewer cleaning nozzles

Rotating nozzles RT . 1,000 bar

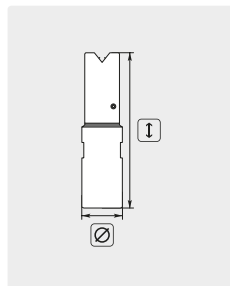

1/8" F. Side jet 2. Front jet 2. Stainless steel.
Rotating body hp-bronze. Compact model, universally applicable. Extreme cleaning performance, removes hard deposits. **1** 80 mm. **∅** 12 mm. Weight 0.18 kg.
Max. 1,000 bar

R+M Nr.	↔
652 710 006	6 l / 100 bar
652 710 012	12 l / 100 bar
652 710 014	14 l / 100 bar

Rotating nozzles RH . 1,000 bar

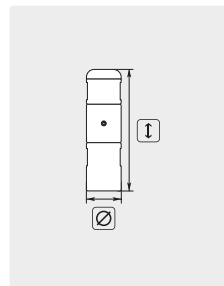

1/8" F. Side jet 2. Stainless steel. Rotating body hp-bronze. Compact model, universally applicable. Extreme cleaning performance, removes hard deposits. **1** 63 mm. **∅** 12 mm. Weight 0.18 kg.
Max. 1,000 bar

R+M Nr.	↔
652 810 006	6 l / 100 bar
652 810 010	10 l / 100 bar
652 810 014	14 l / 100 bar

Nozzles for sewer cleaning

Suttner nozzles for sewer cleaning ST-49.3



1/8" F. Nozzle with traction. Stainless steel. Hardened stainless steel body. Compact model, universally applicable. Extreme cleaning performance. **∅** 12 mm.
Max. 500 bar

R+M Nr.	D
200 049 950	05
200 049 970	07

Symbols ↔ length **1** height ⊕ inlet ⊖ outlet DN nominal diameter P pressure **∅** weight ⊙ thread ∅ diameter D thread TYP type ← flow