

## High pressure hoses per metre

## R+M 1 / Bronze

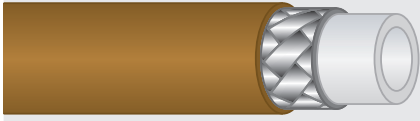

- » Interior polyester / elastomer
- » Very elastic version

- » **Single wire braid**
- » Surface polyurethane

**Field of application:** Semi-professional hp cleaning & pipe cleaning

R+M Nr.	TYP	DN	∅	P	BP	°C
304 20	R+M 1	4	9.2	300 bar	≥ 1,000 bar	-40 °C - +98 °C

## Flexy



- » Interior synthetic rubber
- » Very elastic version

- » **Single wire braid, \* double wire braid**
- » Surface synthetic rubber
- » Abrasion-, oil-resistant and weatherproof

**Field of application:** Professional hp cleaning & pipe cleaning

R+M Nr.	TYP	DN	∅	P	BP	°C
300 95	Flexy 300	6	10.8	300 bar	≥ 800 bar	-40 °C - +100 °C
300 97 *	Flexy 500	6	14.5	600 bar	≥ 2,000 bar	-40 °C - +150 °C

## Sliding Balls Superball / Suttner

For high pressure cleaning hose outer-∅  
12 / 15,8 / 17,5 / 18 mm.  
Set consisting of 1 sliding ball with 2 stainless steel screws.  
Outer-∅ 34 mm

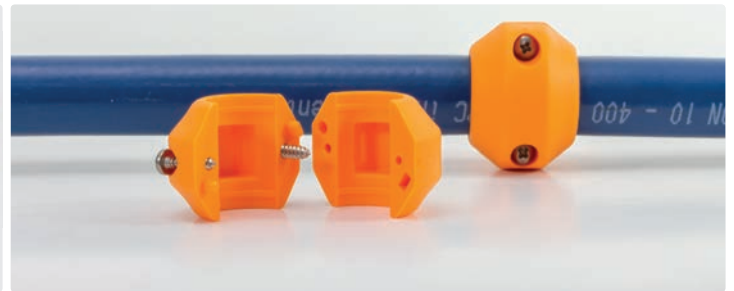
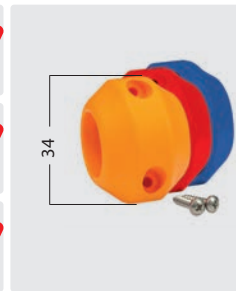

R+M Nr.	C	TYP	for Hose- ∅	Set- VPE	for Hose- (→)
329 191 240	blue	Suttner	12	24	10 m
329 191 370	blue	Suttner	12	37	15 m
329 191 490	blue	Suttner	12	49	20 m
329 191 610	blue	Suttner	12	61	25 m
329 192 240	orange	Suttner	15,8	24	10 m
329 192 370	orange	Suttner	15,8	37	15 m
329 192 490	orange	Suttner	15,8	49	20 m
329 192 610	orange	Suttner	15,8	61	25 m
329 193 240	red	Suttner	17,5	24	10 m
329 193 370	red	Suttner	17,5	37	15 m
329 193 490	red	Suttner	17,5	49	20 m
329 193 610	red	Suttner	17,5	61	25 m
329 190 240	orange	Superball	19	24	10 m
329 190 370	orange	Superball	19	37	15 m
329 190 490	orange	Superball	19	49	20 m
329 190 610	orange	Superball	19	61	25 m

## Hose bend restrictor

## Hose bend restrictor - elastomer, short

Special material which is substantially more UV- and ozone-resistant than usual rubber.  
Conical fit



DN	∅ 1	∅ 2	R+M Nr.	R+M Nr.	R+M Nr.
6	15,1	15,5	308 50	308 51	308 53

## Packing units

Hose bend restrictor - elastomer	175 pieces
Hose bend restrictor - elastomer short	350 pieces